

## ECT100-NP

### Cable Tray 100mm Non Perforated

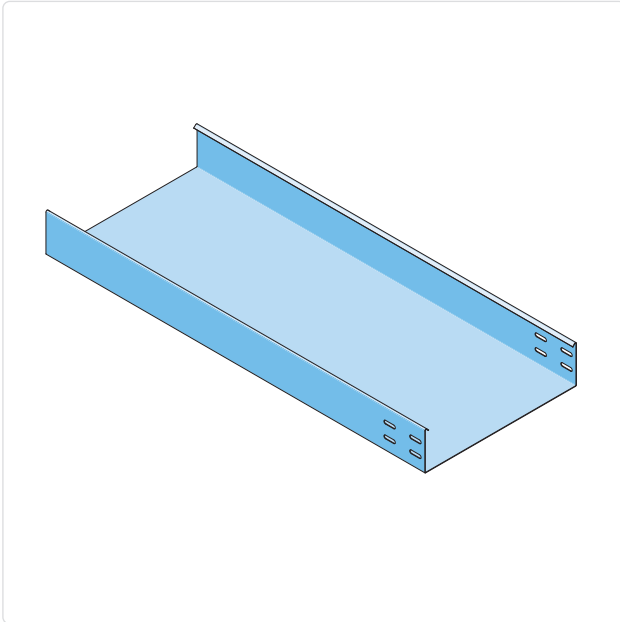

- ✓ Standard execution **hot dip galvanized carbon steel** in accordance with NEN-EN-ISO 1461
- ✓ High zinc coating thickness of **at least 60 µm**
- ✓ Also available in **pre-galvanized, stainless steel 316L** and **stainless steel 304**
- ✓ Standard width 100 - 600 mm
- ✓ Standard radius for accessories 50 mm
- ✓ Standard angles for accessories 45° and 90°
- ✓ Other widths, angles and radii available on request

#### Description

The ECT100-NP cable tray is a closed cable support system for routing and supporting power and data cables in heavy industrial, utility, and infrastructure installations. The non-perforated design is specifically intended for applications where additional mechanical protection of cables is required or where the ingress of dirt, dust, and moisture must be minimized. The cable tray is suitable for wall and ceiling mounting in robust installations.

The standard execution is manufactured from hot-dip galvanized carbon steel in accordance with NEN-EN-ISO 1461, with a zinc coating thickness of at least 60 µm, making it suitable for heavy industrial and outdoor environments. The hot-dip galvanizing process is applied after fabrication and provides complete surface protection, including cut edges. This makes the system suitable for applications with increased mechanical loads and corrosive influences, in accordance with IEC 61537 and installations according to NEN 1010.

The cable tray features a closed U-profile without bottom perforation, resulting in increased cable protection and a rigid construction. The execution is compatible with the Eurostrut ECT100 system and can be expanded with matching splice plates, bends, T-pieces, outside risers, and covers. Installation is possible using standard wall, ceiling, and suspension brackets from the Eurostrut range.

## Technical specifications

<b>Product type:</b>	Closed cable tray, non-perforated
<b>System:</b>	ECT100
<b>System height:</b>	100 mm
<b>System width:</b>	100 to 600 mm
<b>Material thickness:</b>	0.8 to 1.2 mm
<b>Length:</b>	3000 mm
<b>Effective length:</b>	3000 mm
<b>Perforation side:</b>	30 x 8.5 mm (for mounting)
<b>Standard material:</b>	Carbon steel
<b>Surface treatment:</b>	Hot-dip galvanized in accordance with NEN-EN-ISO 1461
<b>Zinc coating thickness:</b>	Minimum 60 µm
<b>Execution:</b>	Closed U-profile without bottom perforation
<b>Standards:</b>	IEC 61537, applicable within installations in accordance with NEN 1010
<b>With cover:</b>	No
<b>Side perforation:</b>	No (for mounting only)
<b>Bottom perforation:</b>	No
<b>Model:</b>	Without connector
<b>Connection method:</b>	Bolted

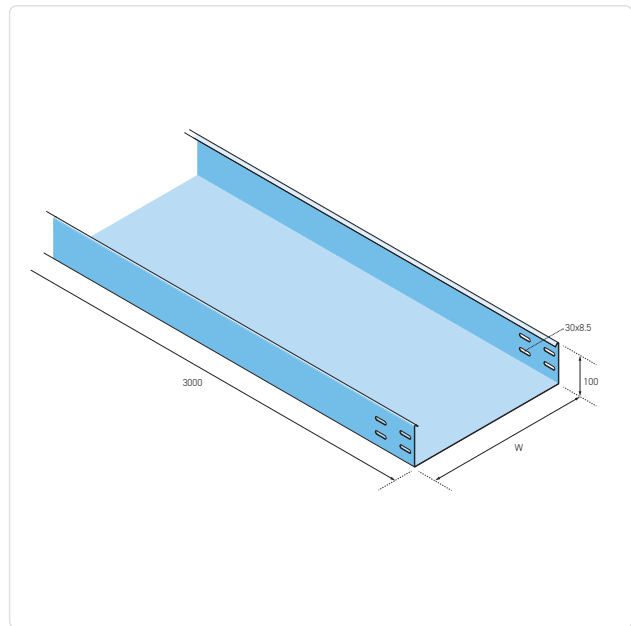

## Available material variants

**PG:** Pre-galvanized steel (EN 10346), suitable for dry indoor environments and light industrial applications.

**HDG:** Hot-dip galvanized carbon steel in accordance with NEN-EN-ISO 1461, with a high coating thickness of at least 60 µm, suitable for heavy industrial and outdoor environments.

**SS 304 (A2 / 1.4301):** Stainless steel for indoor environments and lightly corrosive conditions.

**SS 316L (A4 / 1.4404):** Stainless steel with increased corrosion resistance for chemical, maritime, and offshore applications.

*Other lengths and widths available on request.*

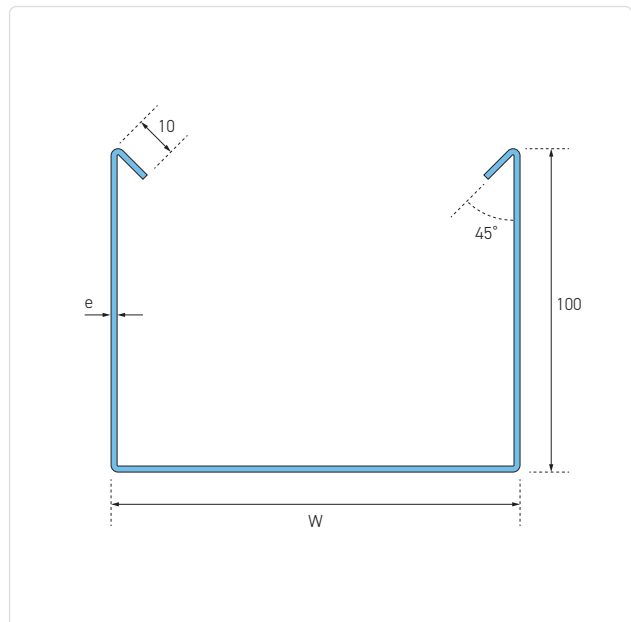

### Load diagram

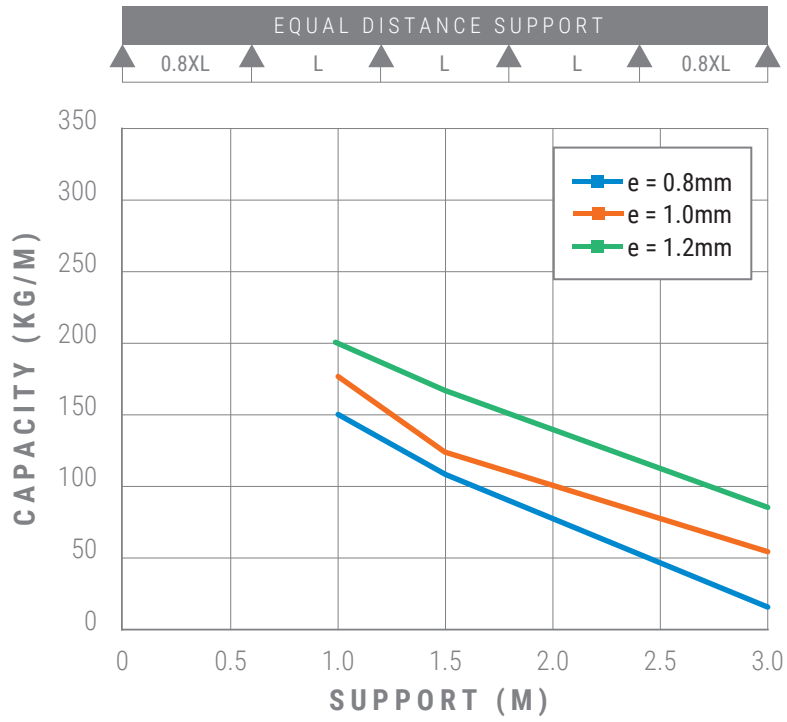

## Variants

Article number	L mm	W mm	H mm	e mm	kg/unit
ECT100-100-HDG-NP	3000	100	100	1.0	7.44
ECT100-150-HDG-NP	3000	150	100	1.0	8.64
ECT100-200-HDG-NP	3000	200	100	1.0	9.84
ECT100-300-HDG-NP	3000	300	100	1.0	12.24
ECT100-400-HDG-NP	3000	400	100	1.2	17.54
ECT100-500-HDG-NP	3000	500	100	1.2	20.42
ECT100-600-HDG-NP	3000	600	100	1.2	23.30

Available material variants	Change HDG to
Hot dip galvanized	-
Pre-galvanized (PG)	PG
Stainless steel A4 / 316L	SS316
Stainless steel A2 / 304	SS304

## Material thickness

Article number	e mm	Article number	e mm	Article number	e mm
ECT100-075-PG-NP	1.0	ECT100-075-SS316-NP	0.8	ECT100-075-SS304-NP	0.8
ECT100-100-PG-NP	1.0	ECT100-100-SS316-NP	0.8	ECT100-100-SS304-NP	0.8
ECT100-150-PG-NP	1.0	ECT100-150-SS316-NP	0.8	ECT100-150-SS304-NP	0.8
ECT100-200-PG-NP	1.0	ECT100-200-SS316-NP	0.8	ECT100-200-SS304-NP	0.8
ECT100-300-PG-NP	1.0	ECT100-300-SS316-NP	1.0	ECT100-300-SS304-NP	1.0
ECT100-400-PG-NP	1.2	ECT100-400-SS316-NP	1.0	ECT100-400-SS304-NP	1.0
ECT100-500-PG-NP	1.2	ECT100-500-SS316-NP	1.2	ECT100-500-SS304-NP	1.2
ECT100-600-PG-NP	1.2	ECT100-600-SS316-NP	1.2	ECT100-600-SS304-NP	1.2

Overview ECT Cable Tray 100 mm

