

EPC-XL Pacman Clamp XL HDG

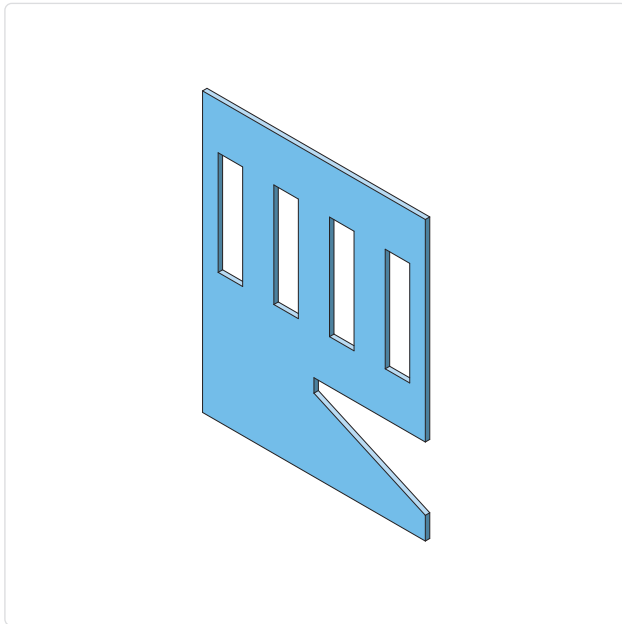

- ✓ Standard execution **hot-dip galvanized carbon steel** in accordance with NEN-EN-ISO 1461
- ✓ High zinc coating thickness of **at least 60 µm**
- ✓ For fast and **drill-free installation** of ECL100 and ECL150 on a H-beam

Description

The EPC-XL pacman clamp is a fixing accessory for cable support systems and is used for mounting cable ladders to steel H-beam structures. The clamp enables drill-free installation and provides a stable and mechanically secure fixation to supporting structures. Specifically suitable for Eurostrut cable ladders ECL100 and ECL150 in industrial and utility installations.

The execution is manufactured from carbon steel and hot-dip galvanized in accordance with NEN-EN-ISO 1461, with a zinc coating thickness of at least 60 µm. This corrosion protection makes the clamp suitable for use in industrial and outdoor environments. The hot-dip galvanizing process is applied after fabrication and protects the entire surface, including cut edges, in accordance with IEC 61537 and installations according to NEN 1010.

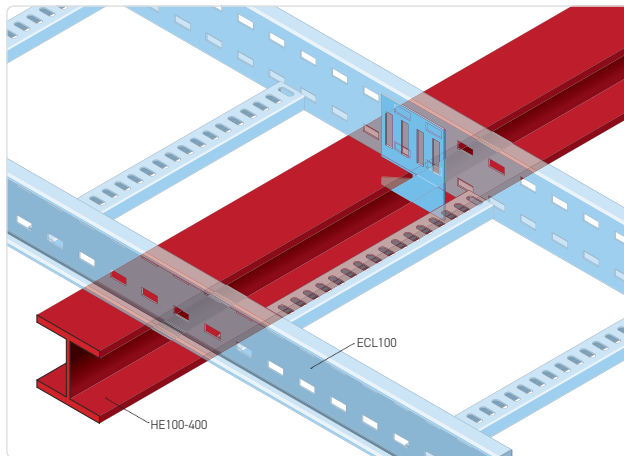

The pacman clamp has a robust construction with a material thickness of 2.0 mm and is suitable for mounting on H-beams with a clamping range from HE100 up to and including HE400. The clamp is placed directly onto the flange of the steel structure and secures itself without additional processing. The execution is fully compatible with Eurostrut cable ladders and associated fixing components.

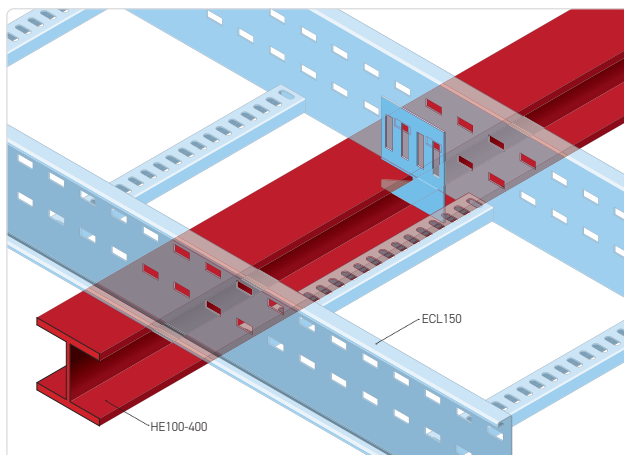

Technical specifications

Product type:	Fixing accessory – pacman clamp size XL
Application:	Drill-free installation on H-beams (steel structures)
Compatibility:	ECL100 and ECL150 cable ladders
Clamping range:	HE100 to HE400
Width:	100 mm
Height:	125 mm
Material thickness (E):	2.0 mm
Material:	Carbon steel
Surface treatment:	Hot-dip galvanized in accordance with NEN-EN-ISO 1461
Zinc coating thickness:	Minimum 60 µm
Standards:	IEC 61537, applicable within installations in accordance with NEN 1010

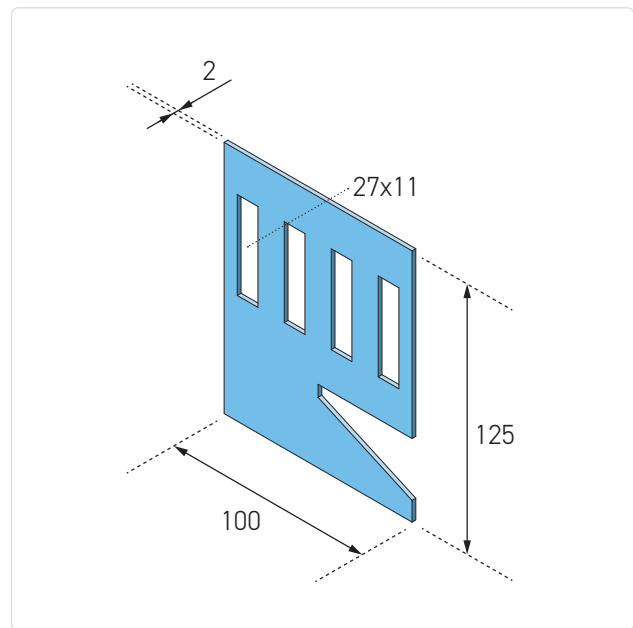

Article number	W mm	H mm	e mm	kg/ unit
EPC-XL-HDG	100	125	2.0	-