

ECTRS100

Straight Connector Cable Tray ECT100

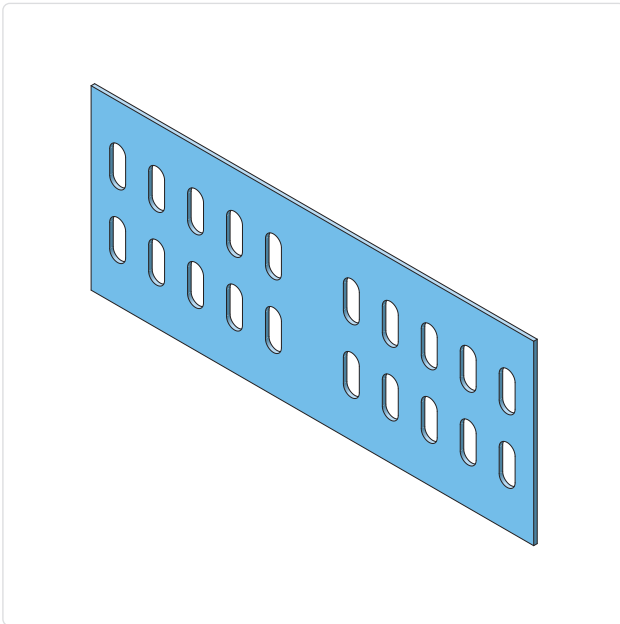

- ✓ Standard execution **hot dip galvanized carbon steel** in accordance with NEN-EN-ISO 1461
- ✓ High zinc coating thickness of **at least 80 µm**
- ✓ Also available in **pre-galvanized, stainless steel 316L** and **stainless steel 304**

Description

The ECTRS100 straight reducer is an accessory for the ECT100 cable tray system and is used to create a symmetrical width transition within cable routes. The reducer enables a gradual transition between cable trays with different widths while maintaining central alignment. This accessory is suitable for heavy industrial, utility, and infrastructure installations.

The standard execution is manufactured from hot-dip galvanized carbon steel in accordance with NEN-EN-ISO 1461, with a zinc coating thickness of at least 80 µm, making it suitable for industrial and outdoor environments. The hot-dip galvanizing process is applied after fabrication and provides complete surface protection, including cut edges and mounting holes. This makes the reducer suitable for applications with increased corrosive and mechanical loads, in accordance with IEC 61537 and installations according to NEN 1010.

The reducer is designed as a fixed accessory for direct connection to straight ECT100 cable trays. To create a complete width transition, this straight reducer can be combined with an additional reducer, such as a left reducer (ECTRL100) or a right reducer (ECTRR100), depending on the required configuration. The design features integrated connectors and is supplied with 8x EFS08x15 fixing set (carriage bolt M08x15, nut and washer), allowing fast installation with proper alignment.

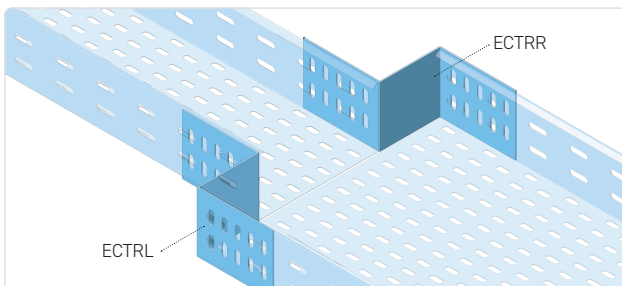
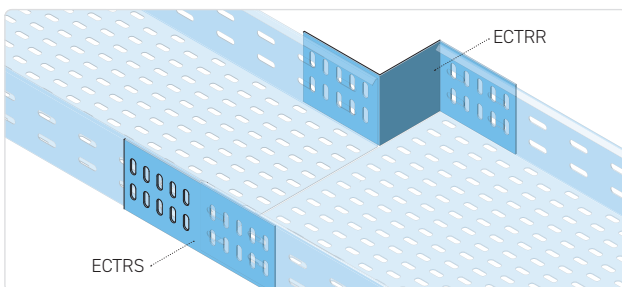
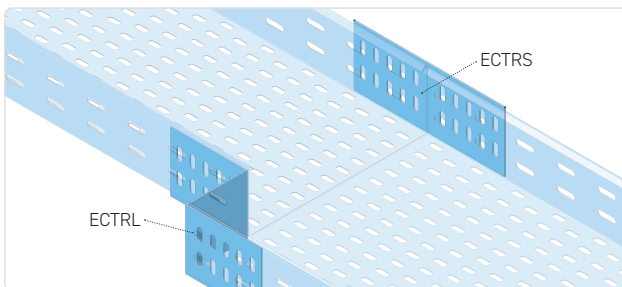

Note: To create a complete width transition, this reducer must always be combined with an additional reducer, depending on the required configuration: a right reducer (ECTRR100) or a left reducer (ECTRL100).

Technical specifications

Product type:	Straight reducer for ECT cable tray
System:	ECT100
System height:	100 mm
Material thickness:	2.0 mm
Length:	250 mm
Height:	100 mm
Connector perforation:	22 × 9 mm
Standard material:	Carbon steel
Surface treatment:	Hot-dip galvanized in accordance with NEN-EN-ISO 1461
Zinc coating thickness:	Minimum 80 µm
Connection method:	Bolted
Execution:	With integrated connectors, including 8x EFS08x15 fixing set (carriage bolt M08x15, nut and washer)
Standards:	IEC 61537, applicable within installations in accordance with NEN 1010
Construction type:	Reduction straight

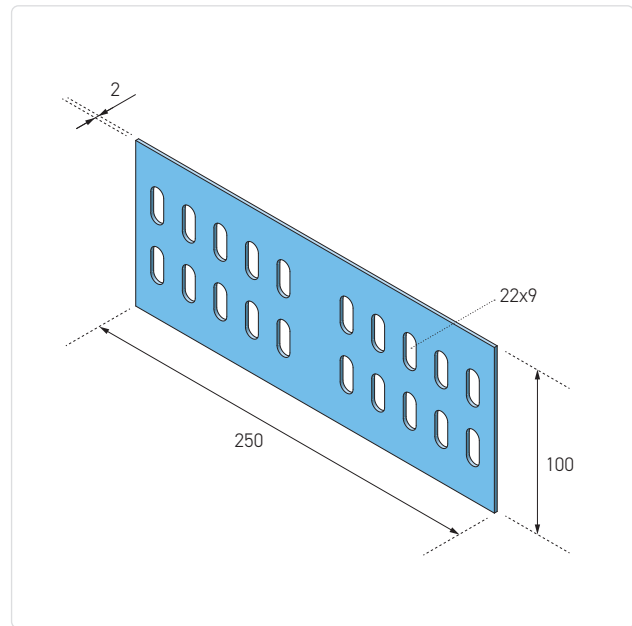

Available material variants

PG: Pre-galvanized steel (EN 10346), suitable for dry indoor environments and light industrial applications.

HDG: Hot-dip galvanized carbon steel in accordance with NEN-EN-ISO 1461, with a high coating thickness of at least 80 µm, suitable for heavy industrial and outdoor environments.

SS 304 (A2 / 1.4301): Stainless steel for indoor environments and lightly corrosive conditions.

SS 316L (A4 / 1.4404): Stainless steel with increased corrosion resistance for chemical, maritime, and offshore applications.

Variants

Article number	L mm	H mm	e mm	kg/ unit
ECTRS100-HDG	250	100	2.0	0.77
ECTRS100-PG	250	100	2.0	0.77
ECTRS100-SS304	250	100	2.0	0.77
ECTRS100-SS316	250	100	2.0	0.77

